

ASTRO-BRAC SIGNAL MOUNTINGS	T1
Bracket Assy's, Clamp Kits, Arm Kits, Tubes, Hardware Kits	
FREE-SWINGING SIGNAL MOUNTINGS	T2
1-Way, 2-Way, Clusters, Disconnect Hangers, Tethers, Hardware Kits	
RIGID SIDE-OF-POLE	T3
1-Way, 2-Way, Tandem	
RIGID POST TOP	T4
Slip Fitters, Terminal Compartments	
RIGID TENON MOUNT	T5
Plumbizers, Mast Arm Hangers	
SIGN MOUNTINGS	T6
Astro Sign-Brac, Mast Arm Mounts, Span Wire Sign Hangers	
CAMERA MOUNTINGS	T7
Astro-Brac, Mast Arm, Side-of-Pole, Span Wire	
PEDESTRIAN PUSH BUTTONS	T8
Round, Rectangular, Stations, Switches, Signs	
CABINETS	T9
Flasher Controllers, Cabinets, Mounting Assy's, Locks	
BACKPLATES	T10
Vaccum Formed, Flat, Louvered, Split	
POLES & BASES	T11
Pedestal Bases, Plastic Doors, Poles, Caps	
MAST ARMS & POLES	T12
Ornamental Bases, Pole & Arm Clamps, Mast Arms & Poles, ITC Assy's, Foundation Anchors	
TRAFFIC ACCESSORIES	T13
GPL's, Visors, Confirmation Lights, Down Lights	
COMPONENTS	T14
Pipe Fittings, Span Wire, Balance Adjusters, Hubs & Mounting Brackets, Hardware Kits, Banding, Buckles	

Following is a typical example of how to construct a unique part number for ordering. Options such as signal section, band length, stainless upgrade, etc., should be indicated by filling in the blank boxes with specific information as shown below. All part numbers should consist of the base part number and at least a finish or coating suffix.

Example:

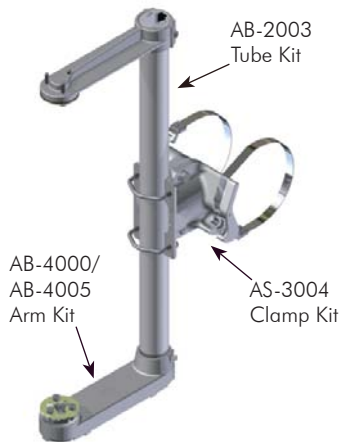

Astro-Brac Assy, Stellar Series, 1-Way Band Mount

AS-0116	-	3	-	29	-	P33
		Signal Section		Band Length		Coating
		1=1 Sec		29=29" Band		PNC=Process No Color
		2=2 Sec		36=36" Band		P__=Paint
		3=3 Sec		42=42" Band		
		4=4 Sec		48=48" Band		
		5=5 Sec		56=56" Band		

Note:
Stainless steel upgrade available: includes stainless clamp screw and slotted washer. Specify by including -SS in the part number, i.e., AS-0116-3-29-SS-PNC.

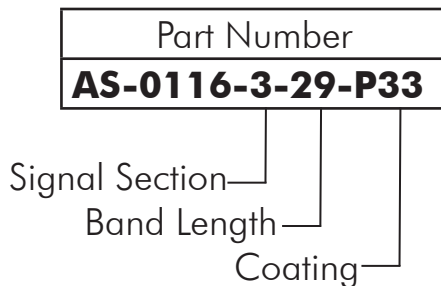

Astro-Brac Assembly, Stellar Mount, 1-Way for 3-Section Signal w/ 29" Bands, Powder Coat Gloss Black

- Pelco's standard products with typical options are shown in this catalog. Special options are often available upon request.
- State Specials and Customer Specific Specials are not included in this catalog.
- All information is assumed to be correct at the time of printing. For the most up-to-date information, please check Pelco's online catalog at www.pelcoinc.com

CODE	COATING
PNC	Process No Color
BOX	Black Oxide
BRS	Brass
CRM	Chrome
EC1	E-coat Black
GLV	Galvanized
ZN1	Zinc Bright
ZN2	Zinc Yellow
P_ _	Paint (add color #)

POWDER COAT STANDARD COLORS	
P29	Federal Yellow
P30	Automatic Green
P33	Gloss Black
P34	Flat Black
P36	New York State Green (forest)
P38	Louisiana Green
P39	Bronze

WET PAINT STANDARD COLORS	
P01	Federal Yellow
P02	Semi-Gloss Black
P03	Flat Black
P04	Gloss Black
P05	New York State Green (forest)
P06	Automatic Green (dark olive)
P16	Industrial Red Primer
P22	Gloss White (industrial enamel)

POWDER COAT SPECIAL COLORS	
(SUBJECT TO SPECIAL SETUP CHARGE)	
P28	Sun Gold (w/ clear top coat)
P32	Clear Coat
P35	Iron Gray
P37	Epoxy Matte Gray Primer
P40	Silver (w/ clear top coat)
P44	Antique Black Matte
P45	Super Wet White
P46	Brown Rust
P47	Brown Base
P48	Gray Primer (zinc rich)
P49	Cratered Pewter
P51	Cratered Bronze
P52	Gold Lame'
P54	Rustic Brown
P55	Copper
P61	Blood Red
P62	MDC Gray
P63	Mocha Brown
P64	KOMO Bronze

Note:

Pelco can match your custom colors.
Please provide the following and contact Pelco for pricing.

- For custom powder: RAL number or paint chip.
- For wet paint: Federal Standard 595 paint code or paint chip.

Special setup and paint charge will apply.

Astro-Brac CLAMP KIT POLE DIAMETERS	
BAND LENGTH	
29"	fits 4" - 8.6" diameter pole
36"	fits 4" - 10.8" diameter pole
42"	fits 4" - 12.7" diameter pole
48"	fits 4" - 14.6" diameter pole
56"	fits 4" - 17.2" diameter pole
72"	fits 4" - 22" diameter pole
84"	fits 17.3" - 26" diameter pole
114"	fits 17.3" - 35" diameter pole
CABLE LENGTH	
62"	fits 4" - 8.6" diameter pole
84"	fits 4" - 11.6" diameter pole
96"	fits 4" - 14.6" diameter pole
110"	fits 4" - 16" diameter pole
120"	fits 4" - 18" diameter pole
132"	fits 4" - 20" diameter pole
144"	fits 4" - 22" diameter pole

TUBE LENGTH Standard & Tri-Bolt Signals	
23"	1-section 12"
37"	2-section 12" & 5-section cluster
46"	3-section 12"
58"	4-section 12"
74"	5-section 12"

TUBE LENGTH 1-1/2" NPS OPS Signals	
50"	3-section 12"
66"	4-section 12"
82"	5-section 12"

Astro-Brac MINI-BRAC CLAMP KITS	
BAND LENGTH	
29"	fits 2" - 8" diameter pole
42"	fits 2" - 12" diameter pole
CABLE LENGTH	
45"	fits 4" - 12" diameter pole
62"	fits 4" - 18" diameter pole
84"	fits 4" - 24" diameter pole

Note:

Circumference to Diameter Conversion

Circumference ÷ pi = Diameter

Example: (12" ÷ 3.14) = 3.82"

PAYMENT TERMS

Net 30 Days.

A 1½% per month (18% APR Service Charge) will be assessed on invoices whose payment has not been received within 45 days.

CREDIT HOLD

Accounts over 90 Days will be placed on credit hold and remain so until brought current including Service Charges. Orders on credit hold will be pulled from production and will only be rescheduled for shipment after release from credit hold.

MINIMUM BILLING

A \$20.00 Minimum Service Charge will be assessed to each order for \$100.00 or less.

F.O.B. POINT

Edmond, Oklahoma unless otherwise quoted.

PRICING

As stated in Price Schedule, *prices are subject to change without notice.*

QUOTATIONS

Pricing on quotations is firm for 30 days from date of quotation unless otherwise indicated. Please reference quotation when ordering.

CANCELLATIONS

Orders cancelled for stock items will be assessed at a minimum of 10% of net value.

Orders cancelled for special or non-stock items will be assessed at a minimum of 20% of net value.

SHIPMENT & DELIVERY

Pelco is very diligent in selecting the most competent and economical carrier. However, upon written request Pelco will use a carrier of your specific choice. See Shipping Notice, in the Reference Section of this catalog, for shipment specifics and freight claims.

RETURNED GOODS

In order to expedite handling, written authorization must accompany all returned goods. Upon request, a Returned Merchandise Authorization (RMA) will be issued and must be used. Use this RMA as a packing list when returning a shipment. A restocking fee plus freight charges shall be assessed against the return of goods unless return of goods was due to an error of Pelco.

REQUESTS FOR CERTIFICATIONS

Representative material test reports are available on request for most Pelco products. If your order contains materials that require lot or heat treat number traceability, or if the materials must be of domestic origin, those requirements must be clearly stated at the time your order is placed.

COPY OF SHIPMENT NOTICE INCLUDED WITH EACH SHIPMENT

NOTICE

SHIPMENTS MADE WITH FACTORY AS F.O.B. POINT

-CARRIER HAS ACCEPTED SHIPMENT IN GOOD CONDITION-
LOST OR DAMAGED GOODS ARE THE CARRIER'S RESPONSIBILITY in all shipments of this type.

PELCO'S Responsibility For This Shipment Has Now Ceased.

CHECK YOUR SHIPMENT CAREFULLY WHEN DELIVERED to see that it is in good order and received complete. When packages check short or are in bad condition, have the Carrier's agent make notation of this fact in detail on the freight bill or express receipt and then require that he sign it.

LOST OR DAMAGED GOODS ARE THE CARRIER'S RESPONSIBILITY in all LTL (less than truckload) shipments. In TL (truckload) shipments, the Carrier is responsible for damage to exposed surfaces of the goods (top and ends) caused by collision with other vehicles or objects when the Carrier is negligent, and by loading other freight on or against Pelco goods. When the trailer itself shows evidence of fresh damage, call at once for inspection of the contents just as though it were an LTL shipment.

CONCEALED LOSS OR DAMAGE DISCOVERED AFTER DELIVERY of shipment must be reported to the delivering Carrier upon discovery, and in any event within 15 days after receipt. Hold goods, containers, and packing materials in exact condition as found for inspection by the Carrier. An inspector for the Carrier should call within 48 hours. If nothing is heard in that time, notify them by registered mail and get a receipt. The Carrier will issue an inspection report and give you a copy which must be used to support your claim.

FAILURE TO COMPLY WITH ANY OF THE FOREGOING REGULATIONS IS REGARDED AS INDICATING COMPLETE DELIVERY OF FREIGHT IN GOOD CONDITION.

Make Your Claim Promptly
Carrier Will Not Consider a Claim Unless Presented Within 9 Months After Receipt of Shipment.

IMPORTANT!

DO NOT DEDUCT THE AMOUNT OF LOSS OR DAMAGE from Pelco invoice while awaiting adjustment of a claim, as we can not guarantee safe delivery for actions beyond our control.

Please do not return goods to Pelco or instruct Carriers to return goods without first securing written authorization and shipping instructions.

SHIPMENTS MADE WITH DESTINATION AS F.O.B. POINT

-CARRIER HAS ACCEPTED SHIPMENT IN GOOD CONDITION-

CHECK YOUR SHIPMENT CAREFULLY WHEN DELIVERED to see that it is in good order and received complete.

When packages check short or are in damaged condition, have the carriers agent make notation of this fact on the freight bill or express receipt, and then require that he sign it.

Check your shipment immediately to make sure the contents agree with the Pelco packing list enclosed and to determine if any damage has occurred during transit.

Any shortages and or concealed damages MUST be reported to Pelco within 10 DAYS.

FAILURE TO COMPLY WITH THE FOREGOING IS REGARDED AS AN INDICATION THAT YOUR SHIPMENT HAS ARRIVED IN SATISFACTORY CONDITION AND THAT IT IS COMPLETE AS SHOWN ON OUR PACKING LIST.

Please do not return damaged goods to Pelco without first securing authorization and shipping instructions.

Pelco will make every effort possible to effect prompt correction of any short or damaged goods when claims are made within these guidelines.



320 W. 18th
Edmond, OK 73013
(405)340-3434 FAX:(405)340-3435

WARRANTY

General: All statements, technical information and recommendations contained in Pelco Product Brochures and Bulletins are based on tests Pelco believes to be reliable. However, the accuracy or completeness thereof is not guaranteed and the following is made in lieu of all warranties, expressed or implied:

Limited Warranty: Pelco's only obligations shall be to replace such quantity of the product proven to be defective.

Repair or replacement of any product will be made at Pelco's facilities. The extent of repair or replacement is at Pelco's discretion. Transportation to and from Pelco's facilities is the responsibility of the buyer.

Pelco shall not be liable for injury, loss or damage direct or consequential arising out of the use of, or the inability to use the product. Before using, user shall determine the suitability of the product for his intended use, and assumes all risk and liability whatsoever in connection therewith. No statement or recommendation not contained herein shall have any effect unless in an agreement signed by the officers of Pelco Products Inc.

Warranty Period: Unless otherwise noted, standard product warranty is 12 months from date of shipment.