

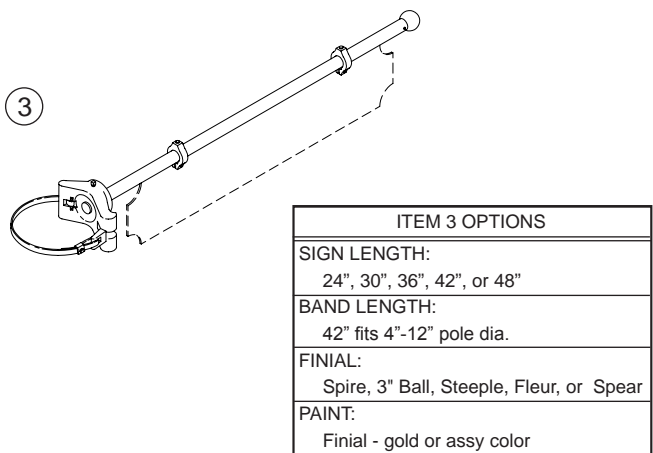

Pelco's Ornamental Street Signs convey important messages to motorists and pedestrians every day of the year. Beauty, durability, and great styling are the hallmarks of Pelco street signs. Whether you need a post top mount, a free-swinging mount or a rigid sign assembly, Pelco has the sign combination to make your project unique.

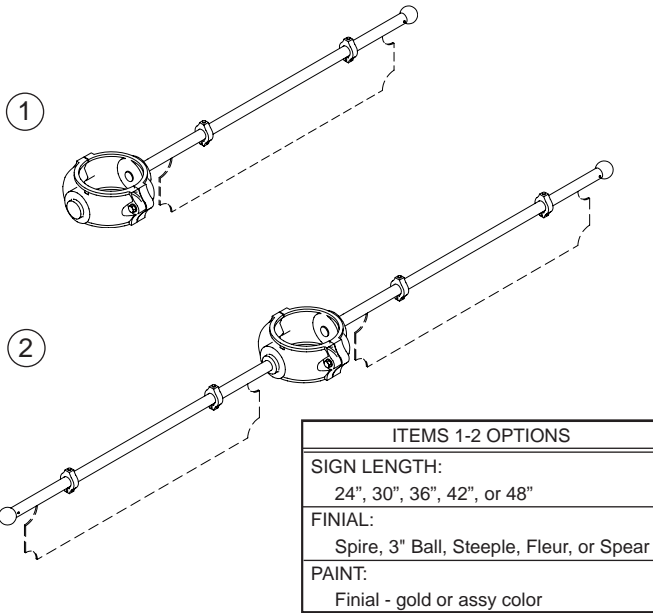



ITEM	DESCRIPTION	PART NO.
------	-------------	----------

- ① RIGID SIGN MOUNT ASSY, 1-WAY:  
 For 2" (2-3/8" OD) Pole..... AP-7290  
 For 2½" (2-7/8" OD) Pole ..... AP-7240  
 For 3" (3½" OD) Pole..... AP-7241  
 For 4" (4½" OD) Pole..... AP-7242  
 For 3" Fluted (4.06" OD) Pole ..... AP-7243  
 For 4" Fluted (5.08" OD) Pole ..... AP-7244

- ② RIGID SIGN MOUNT ASSY, 2-WAY:  
 For 2" (2-3/8" OD) Pole..... AP-7295  
 For 2½" (2-7/8" OD) Pole ..... AP-7285  
 For 3" (3½" OD) Pole..... AP-7286  
 For 4" (4½" OD) Pole..... AP-7287  
 For 3" Fluted (4.06" OD) Pole ..... AP-7288  
 For 4" Fluted (5.08" OD) Pole ..... AP-7289

- ③ RIGID SIGN MOUNT ASSY, 1-WAY:  
 W/ Astro Mini-Brac ..... AP-7268

Notes:

1. All assemblies are supplied standard with stainless fasteners.
2. For street name signs available see section 8 page 4.
3. Please specify options when ordering.

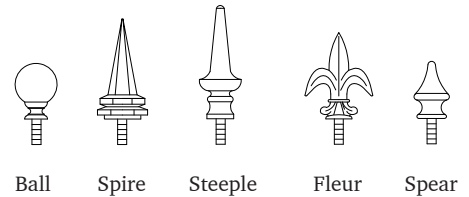

Finial Options



Rigid Post Top Mount

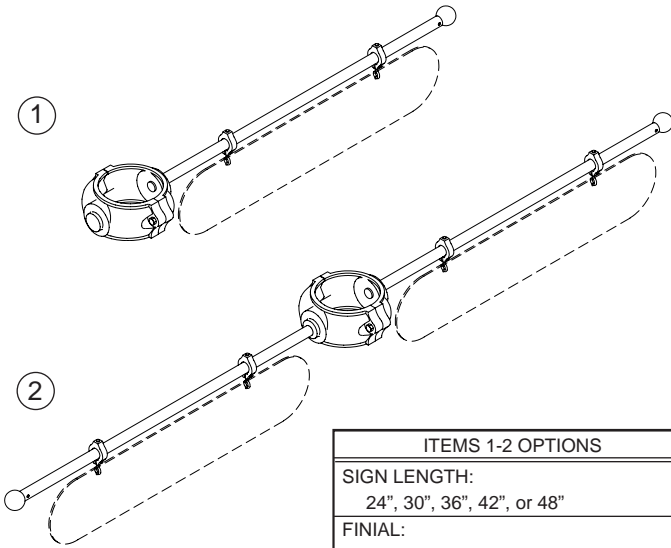

ITEMS 1-2 OPTIONS	
SIGN LENGTH:	24", 30", 36", 42", or 48"
FINIAL:	Spire, 3" Ball, Steeple, Fleur, or Spear
PAINT:	Finial - gold or assy color

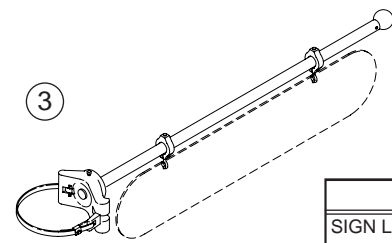
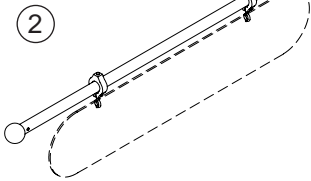

ITEM 3 OPTIONS	
SIGN LENGTH:	24", 30", 36", 42", or 48"
BAND LENGTH:	42" fits 4"-12" pole dia.
FINIAL:	Spire, 3" Ball, Steeple, Fleur, or Spear
PAINT:	Finial - gold or assy color

ITEM	DESCRIPTION	PART NO.
------	-------------	----------

①	FREE-SWINGING SIGN MOUNT ASSY, 1-WAY:	
	For 2" (2-3/8" OD) Pole.....	AP-7293
	For 2½" (2-7/8" OD) Pole .....	AP-7245
	For 3" (3½" OD) Pole.....	AP-7246
	For 4" (4½" OD) Pole.....	AP-7247
	For 3" Fluted (4.06" OD) Pole .....	AP-7248
	For 4" Fluted (5.08" OD) Pole .....	AP-7249
②	FREE-SWINGING SIGN MOUNT ASSY, 2-WAY:	
	For 2½" (2-7/8" OD) Pole .....	AP-7269
	For 3" (3½" OD) Pole.....	AP-7270
	For 4" (4½" OD) Pole.....	AP-7271
	For 3" Fluted (4.06" OD) Pole .....	AP-7272
	For 4" Fluted (5.08" OD) Pole .....	AP-7273
③	FREE-SWINGING SIGN MOUNT ASSY, 1-WAY:	
	W/ Astro Mini-Brac .....	AP-7292

Notes:

1. All assemblies are supplied standard with stainless fasteners.
2. For street name signs available see section 8 page 4.
3. Please specify options when ordering.

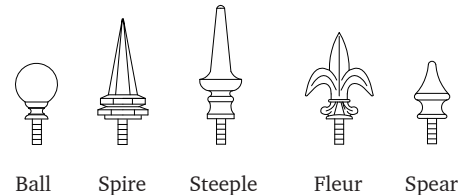

Finial Options



Free-Swinging Mount



Rigid Mount

- ① **POPLAR** PL
- ② **ADAMS** AVE
- ③ **MAIN** ST
- ④ **FIRST** ST

ITEM	DESCRIPTION	PART NO.
STREET NAME SIGN, RIGID or FREE-SWINGING MOUNT: 6" 9"		
①	Reflective Background, White Reflective Legend .....	SF-5032 SF-5041
	Powder Coat Background, White Reflective Legend ...	SF-5033 SF-5042
②	Reflective Background, White Reflective Legend .....	SF-5007 SF-5045
	Powder Coat Background, White Reflective Legend ...	SF-5008 SF-5046
STREET NAME SIGN, EXTRUDED: 6" 9"		
③	Reflective Background, White Reflective Legend .....	SF-5000 SF-5047
	Powder Coat Background, White Reflective Legend ...	SF-5011 SF-5048
④	Reflective Background, White Reflective Legend .....	SF-5034 -
	Powder Coat Background, White Reflective Legend ...	SF-5020 -

Notes:

- Please specify options when ordering.

ITEM 1-4 OPTIONS
SIGN LENGTH: 24", 30", 36", 42", or 48"
BACKGROUND:
ENG GRADE REFLECTIVE: Green, Brown, or Blue
HI INTENSITY REFLECTIVE: Green, Brown, or Blue
DG3 REFLECTIVE: Green, Brown, or Blue
PAINT:
LEGEND:



ITEM	DESCRIPTION	PART NO.
①	<b>SLOTTED ADAPTER:</b> For Extruded Sign Blades .....	SH-1813
②	<b>POST CAP w/ FINIAL:</b> For 2" (2-3/8" OD) Pole..... For 2½" (2-7/8" OD) Pole .....	SH-1808 SH-1828
	For 3" OD Pole .....	SH-1840
	For 3" (3-1/2" OD) Pole.....	SH-1617
	1½" NPS .....	SH-1820
③	<b>POST CAP FOR EXTRUDED BLADES:</b> For 2" (2-3/8" OD) Pole w/ 5" Slots .....	SH-1800
	For 2½" (2-7/8" OD) Pole w/ 5" Slots .....	SH-1829
	For 4" (4-1/2" OD) Pole w/ 5" Slots .....	SH-1608
④	For 2" (2-3/8" OD) Pole w/ 12" Slots .....	SH-1845
⑤	For 2" Square Pole w/ 12" Slots .....	SH-1846
	<b>CROSS:</b>	
⑥	90° w/ 5" Slots for Extruded Blades .....	SH-1801
	90° w/ 6" Slots for Extruded Blades .....	SH-1848
⑦	90° w/ 12" Slots for Extruded Blades .....	SH-1847
⑧	<b>POST TOP STREET NAME SIGN MOUNT</b> 90° Underbraced w/ 12" Slots for 9" Extruded Blades .....	SH-1844
⑨	<b>ADJUSTABLE CROSS:</b> For Extruded Sign Blades, 45° & 180° .....	SH-1852
⑩	<b>SIGN POST:</b> For 2" (2-3/8" OD) Post, Steel, 10'-0" .....	PB-5208
	For 2½" (2-7/8" OD) Post, Steel, Sch 10 x 10'-0" .....	AP-2072



ITEM 1-2 OPTIONS	
FINIAL:	3" Ball, Spire, Steeple, Fleur, or Spear
PAINT:	Finial - gold or assy color



Finial Options

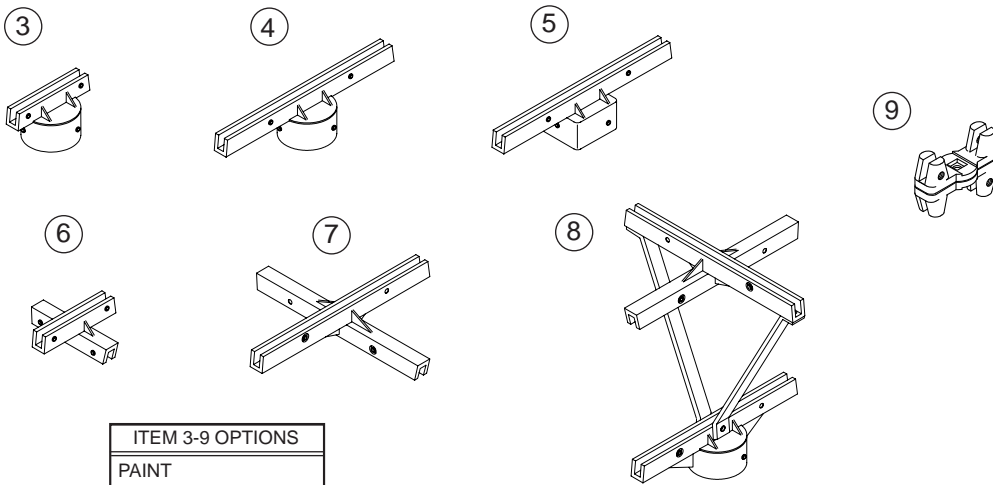

ITEM 3-9 OPTIONS	
PAINT	

Notes:

- All assemblies are supplied standard with stainless fasteners.
- Please specify options when ordering.



ITEM	DESCRIPTION	PART NO.
①	WAY-FINDING SIGN MOUNT ASSY, 2-WAY: For 3" (3½" OD) Pole.....	AP-7298
②	WAY-FINDING SIGN, EXTRUDED: Powdercoat Background, White Reflective Legend .....	SF-5049
③	LOGO PLATE, WAY FINDING Powdercoat Background w/ Legend .....	SF-5050

Notes:

1. Specify options and legend required when ordering.
2. For use on AP-0220 Pole. See Section 4 Page 8.

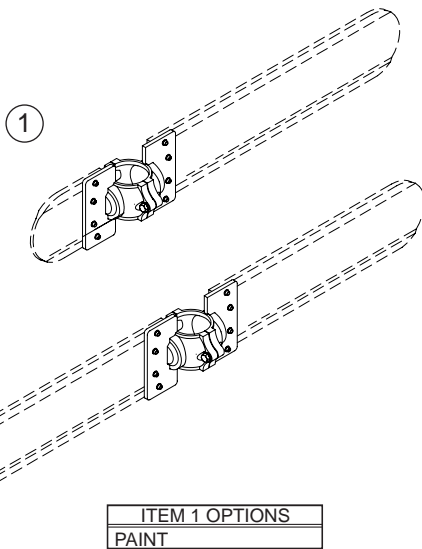

ITEM 2 OPTIONS
SIGN LENGTH: 6", 24", 30", 36", 42", or 48"
PAINT

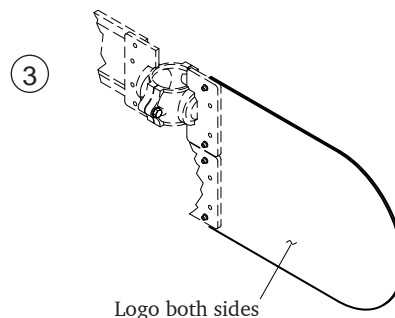

ITEM 3 OPTIONS
LOGO
PAINT



ITEM	DESCRIPTION	PART NO.
①	STOP SIGN, Alum w/ 3/8" Mounting Holes, Reflective .....	SF-6000
②	12" SIGN, Alum w/ 3/8" Mounting Holes Powdercoat Background w/ White Reflective Legend.....	SF-5031
③	18" SIGN, Alum w/ 3/8" Mounting Holes Powdercoat w/ White Reflective Background.....	SF-5016
④	24" SIGN, Alum w/ 3/8" Mounting Holes Powdercoat Background w/ White Reflective Legend.....	SF-5027
⑤	24" SIGN, Alum w/ 3/8" Mounting Holes White Reflective Background .....	SF-5014
⑥	36" SIGN, Alum w/ 7/16" Mounting Holes White Reflective Background .....	SF-5028

Notes:

1. Please specify options when ordering.
2. Regulatory signs available upon request.

①

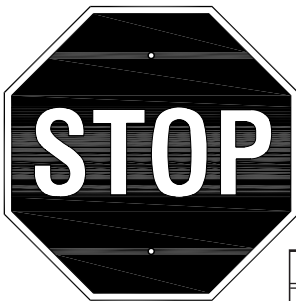

ITEM 1 OPTIONS
SIZE: 24", or 30"
BLACK BACK
HIGH INTENSITY
DG3

②



ITEM 2 OPTIONS
SIGN HEIGHT: 9", 12", or 18"
BORDER: 3/8" Wide
PAINT

④



ITEM 4 OPTIONS
SIGN HEIGHT: 24", 30" or 48"
BORDER: 5/8" Wide
PAINT

⑤

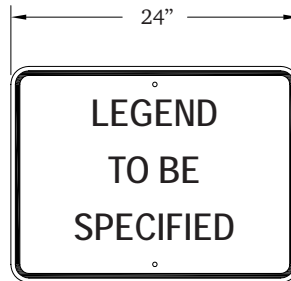

ITEM 5-6 OPTIONS
SIGN HEIGHT: 18", 24", or 30"
BORDER: 5/8" Wide
LEGEND COLOR: Brown, Green, Black, or Blue Reflective, or Red Non-Reflective

③



ITEM 3 OPTIONS
SIGN HEIGHT: 9", 12", 18" or 24"
BORDER: 5/8" Wide
VINYL COLOR: Red
PAINT

⑥

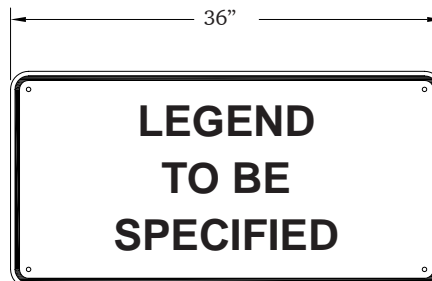

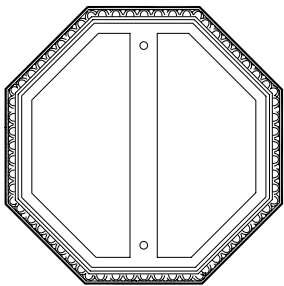

**AP-7012-1**  
Cast Alum Sign Frame  
for 30" Stop Sign  
**AP-7013-1**  
for 24" Stop Sign

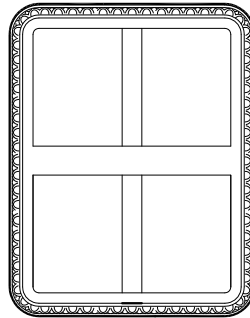

**AP-7011-2**  
Cast Alum Sign Frame  
for 18" x 24" Sign

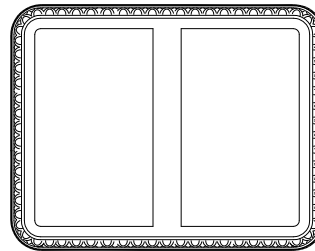

**AP-7228**  
Cast Alum Sign Frame  
for 24" x 18 Sign

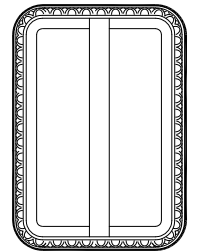

**AP-7215**  
Cast Alum Sign Frame  
for 12" x 18 Sign

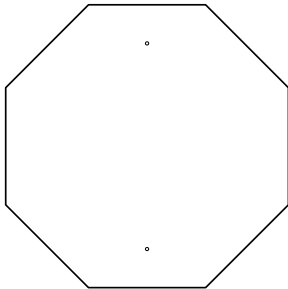

**SH-1849**  
Sign Frame  
for 24" Stop Sign  
**SH-1850**  
for 30" Stop Sign

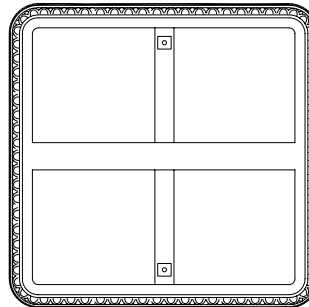

**AP-7237**  
Cast Alum Sign Frame  
for 24" x 24" Sign



**AP-7233**  
Ornamental Corner Bracket  
(For use with rigid and free-swinging sign  
mounts shown on Pages O8-2 and O8-3)

Note:  
For Sign Mounting Kits see Page O8-8.



ITEM	DESCRIPTION	PART NO.
①	DOUBLE SIGN CLAMP: W/ 5/16" Sign Mounting Hardware.....	SH-0203
②	U-BOLT SIGN CLAMP: W/ 5/16" Sign Mounting Hardware.....	SH-0206

Notes:

- All Sign Clamp Assemblies consist of 2 clamp assemblies. (one complete pair per package).

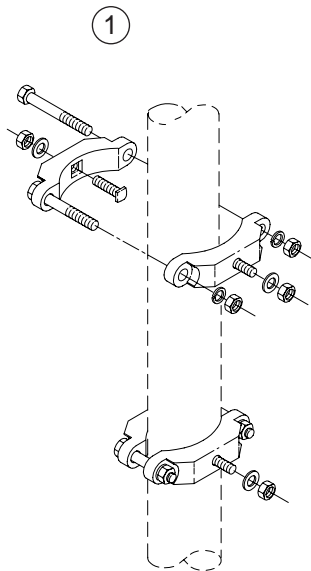

ITEM 1 OPTIONS
POLE SIZE: 1½" (1-7/8" OD) 2" (2-3/8" OD)
PAINT

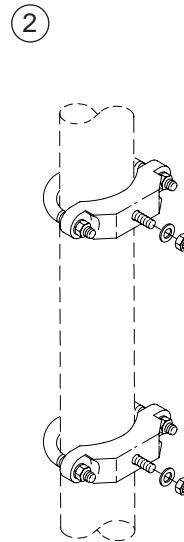

ITEM 2 OPTIONS
POLE SIZE: 1½" (1-7/8" OD) 2" (2-3/8" OD) 2½" (2-7/8" OD) 4" (4½" OD)
MOUNTING SIGNS W/ ORNAMENTAL FRAMES
PAINT



ITEM	DESCRIPTION	PART NO.
------	-------------	----------

All Message Board Assemblies are weatherproof and lock-able, with a clear plexiglass window. Each comes complete with two ornamental hubs for mounting to pole diameters of 2.88" thru 5.08". Available with or without LED lighting. Finished with a durable powder coat in a variety of colors.

**MESSAGE BOARD:**

- ① Illuminated w/ Decorative Scroll, 26" x 20" ..... SH-0113
- ② Non-Illuminated w/ Decorative Scroll, 26" x 20" ..... SH-0109
- ③ Non-Illuminated, 18" x 24" ..... SH-0114

Notes:

1. Please specify pole mounting size required and color when ordering, i.e., SH-0113-3.5-P59 for 3-1/2" O.D. pole mount, powder coated textured black.
2. For available ornamental bases see section O4-1 through O4-4. For poles see section O4-8 and O4-9. For finials see section O8-5

ITEM 1-3 OPTIONS
POLE SIZE:
2½" (2.88" OD) -2.5-
3" (3.5" OD) -3-
4" (4.5" OD) -4-
3" Fluted (4.06" OD) -3F-
4" Fluted (5.08" OD) -4F-
PAINT

① ②

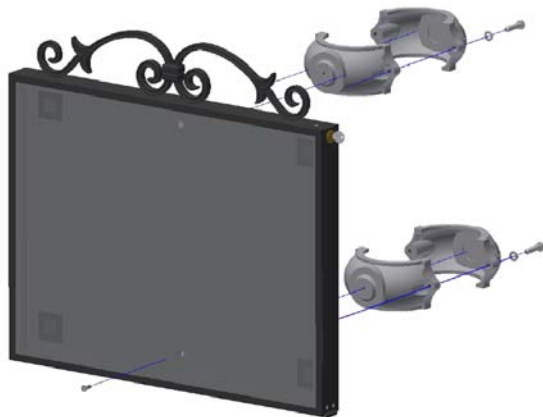

③

